

Tohin Rotary Vane Blower

HC-251s

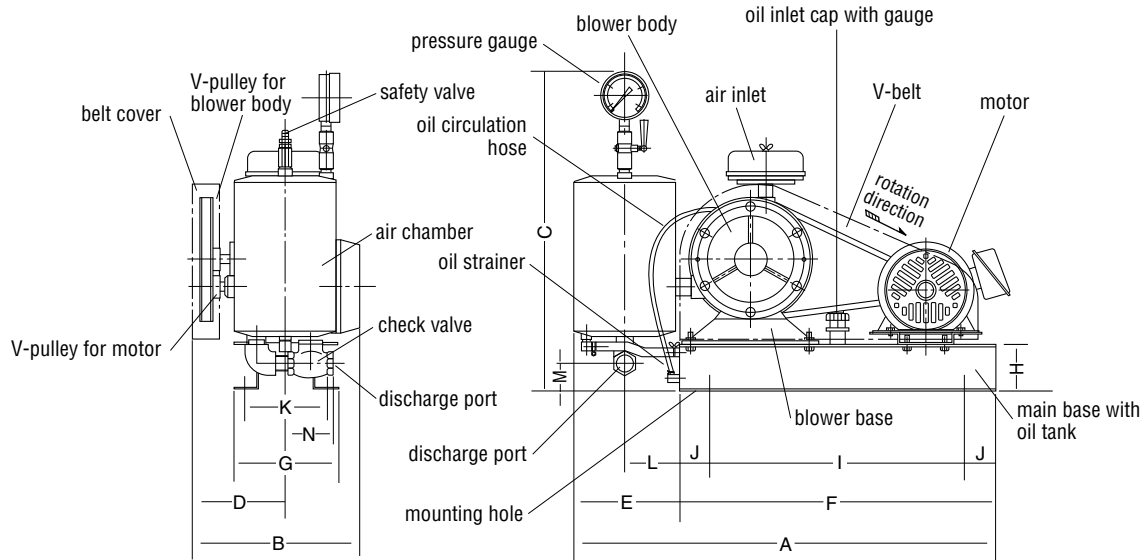

HC-30s, 301s, and 301H

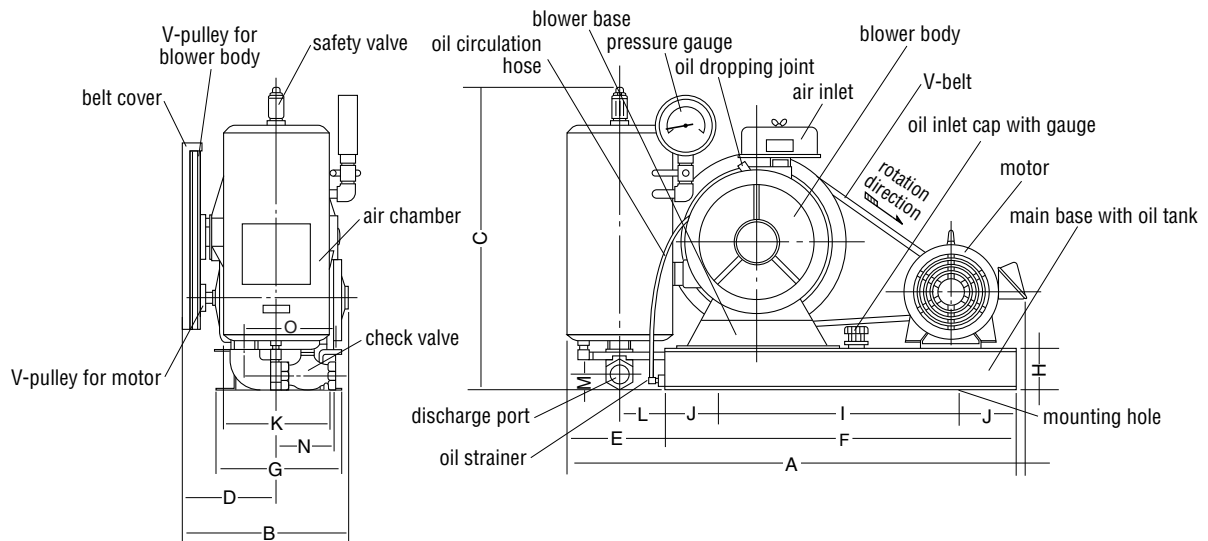

(unit: mm)

Model	A	B	C	D	E	F	G	H	I	J	J ^o	K	L	M	N
HC-251s	679	270	515	149	169	510	170	75	410	50	-	130	87	40	74
HC-30s	686	273	515	160	176	510	170	75	410	50	-	130	90	55	80
HC-301s	686	267	515	160	176	510	170	75	410	50	-	130	90	55	80
HC-301H	686	267	515	160	176	510	170	75	410	50	-	130	90	55	80
HC-40s	779	310	505	184	179	600	230	75	400	100	-	190	88	40	125
HC-401s	779	310	505	184	179	600	230	75	400	100	-	190	88	40	125
HC-50s	1018	339	600	213	218	800	265	75	600	100	-	225	106	60	117
HC-501s	1049	339	600	213	249	800	265	75	600	100	-	225	123	55	117
HC-60s	1180	385	825	233	330	850	300	100	485	125	115	260	185	60	110
HC-80s	1325	440	878	260	325	1000	350	100	580	150	120	310	180	65	166
HC-100s	1500	550	990	325	400	1100	470	150	660	150	140	410	223	70	163

Tohin Rotary Vane Blower

HC-40s and 50s

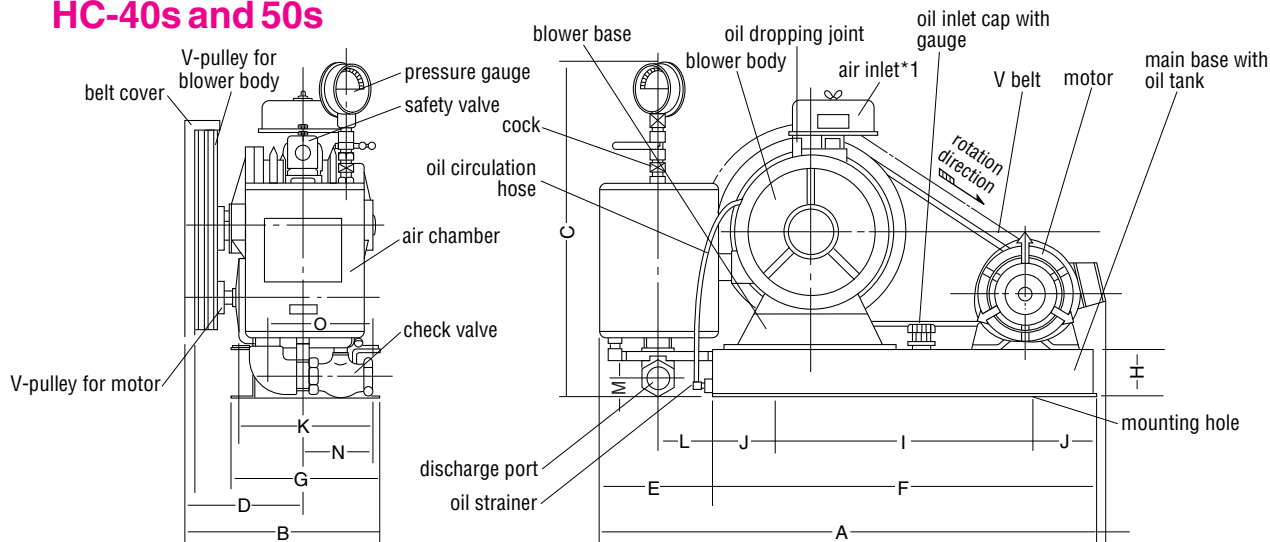

*1: Air inlet of HC-50s is the same as one of HC-501s

HC-501s

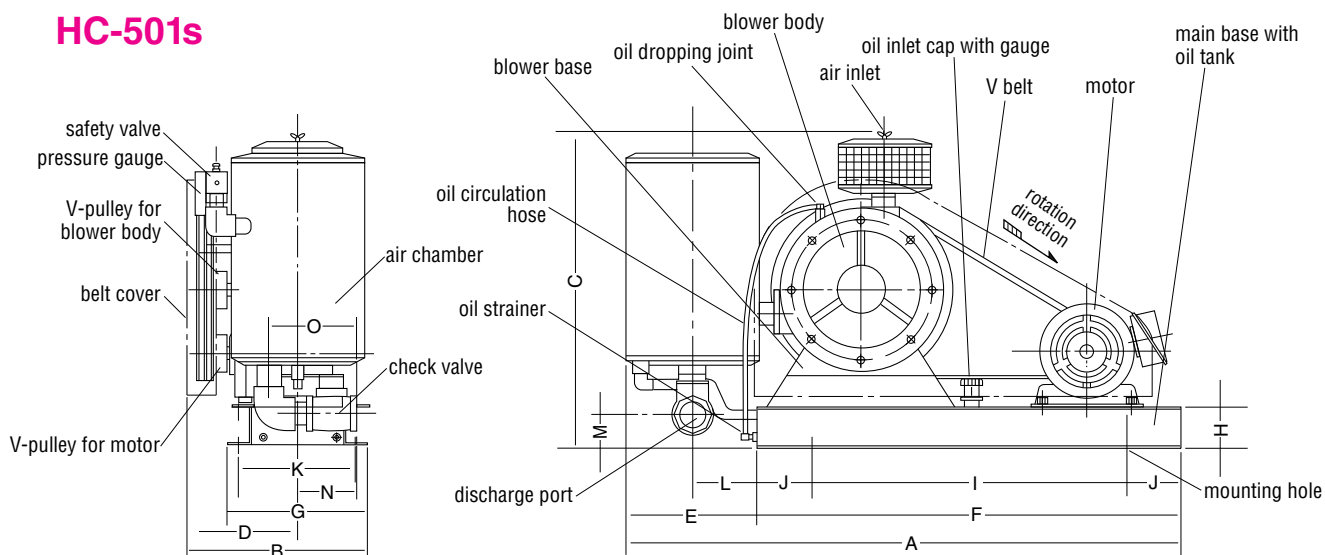

HC-60s, 80s, and 100s

